

BÂCHE 1.70m x 2.50m
SHEET 1.70m x 2.50m
DEKZEIL 1.70m x 2.50m
FOLIE 1.70m x 2.50m

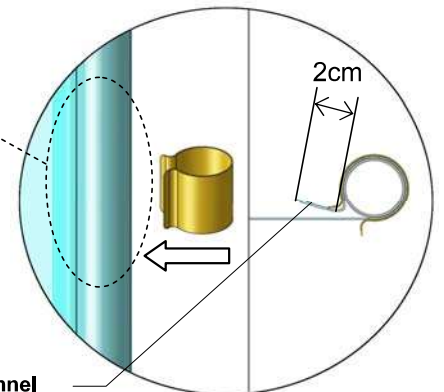

Couper l'excédent de bâche se trouvant à l'intérieur du tunnel
Cut the top of the frame until required height
Snijd het overtollige dekzeil aan de binnenkant van de tunnel weg
Den oberen Teil des Rahmens an gewünschter Höhe durchtrennen

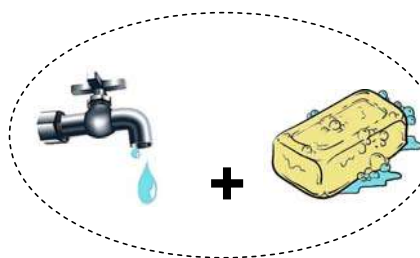
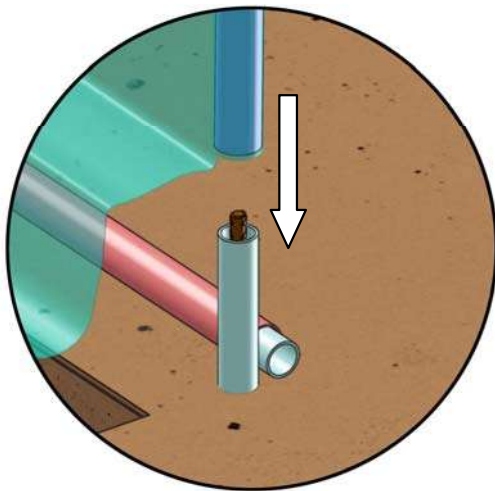
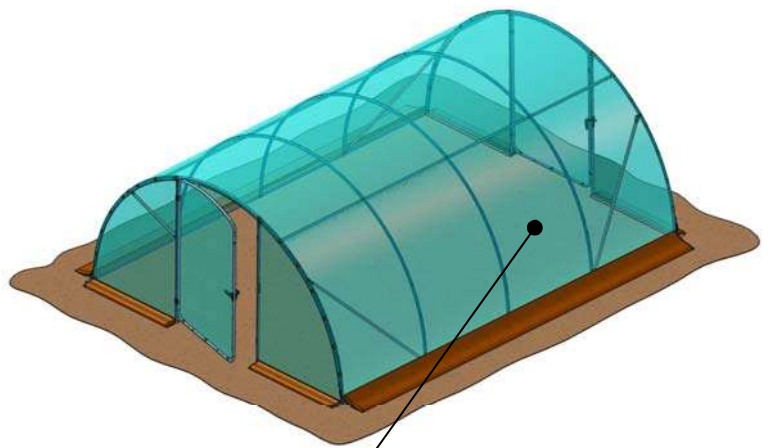

BÂCHE
SHEET
DEKZEIL
FOLIE

P720057

P720057

8.30m

95cm

6.12m

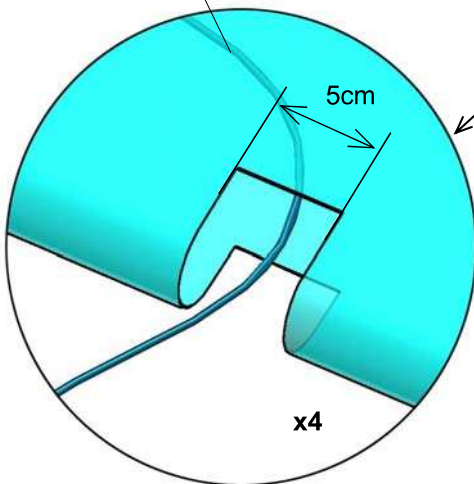

x4



- Faire attention à ne pas endommager le film
- Take care to not damage the film
- Let erop om het zeil niet te beschadigen
- Achten dass die folie nicht beschädigt wird

BÂCHE
SHEET
DEKZEIL
FOLIE

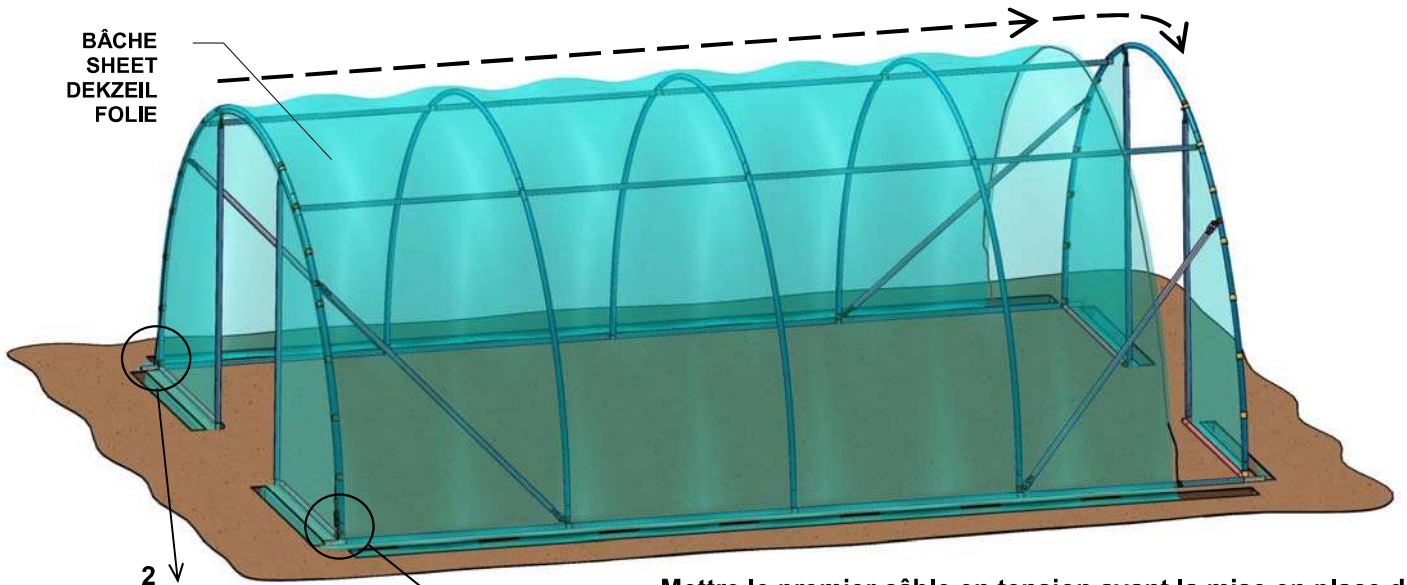

- Mettre le premier câble en tension avant la mise en place du deuxième
- Tight the first cable before putting in place the second
- Trek de eerste kabel strak voordat u de tweede plaatst
- Spannen des ersten Kabels bevor das zweite angebracht wird

P720057

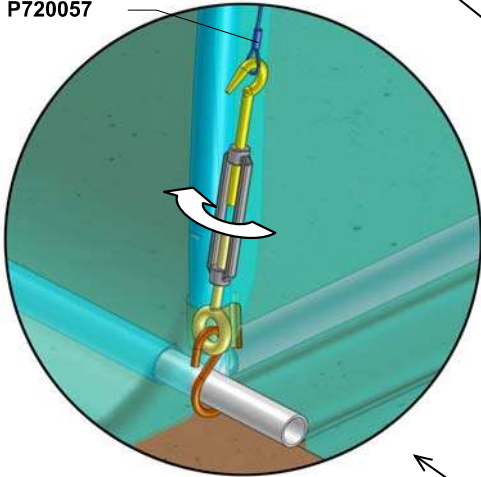

1

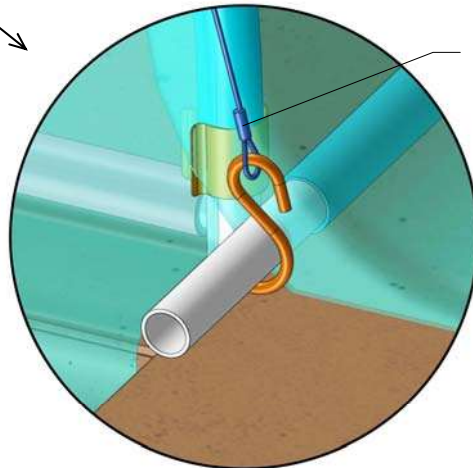

P720057

4

3

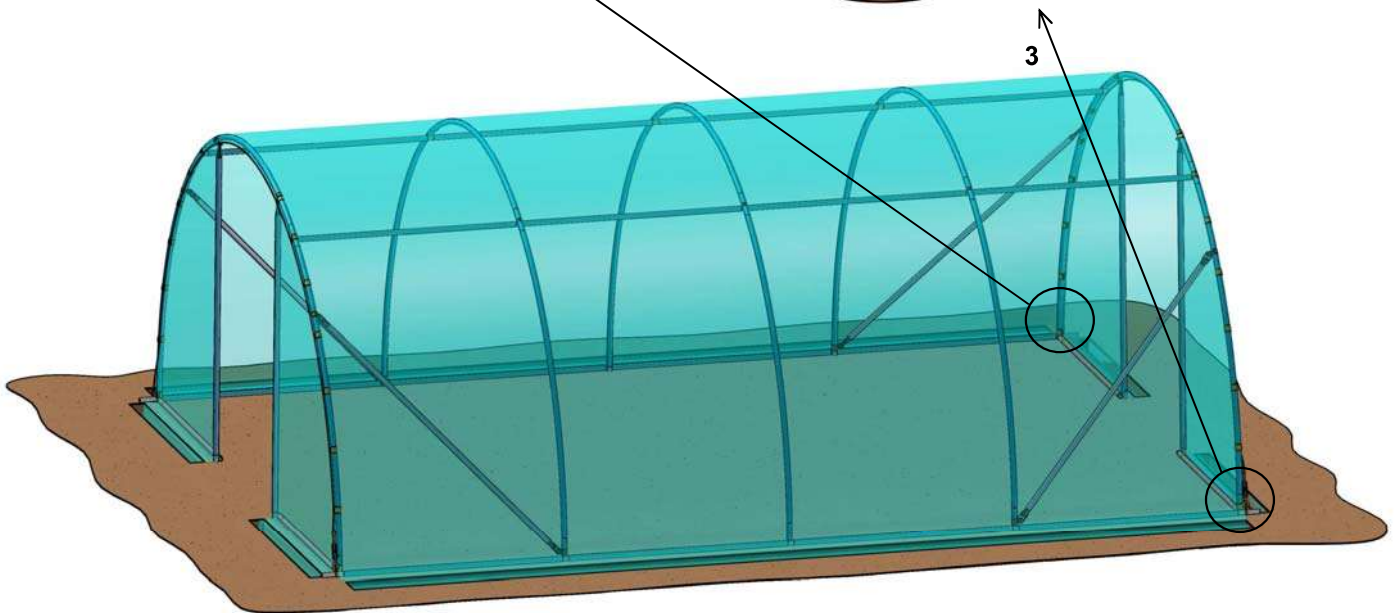

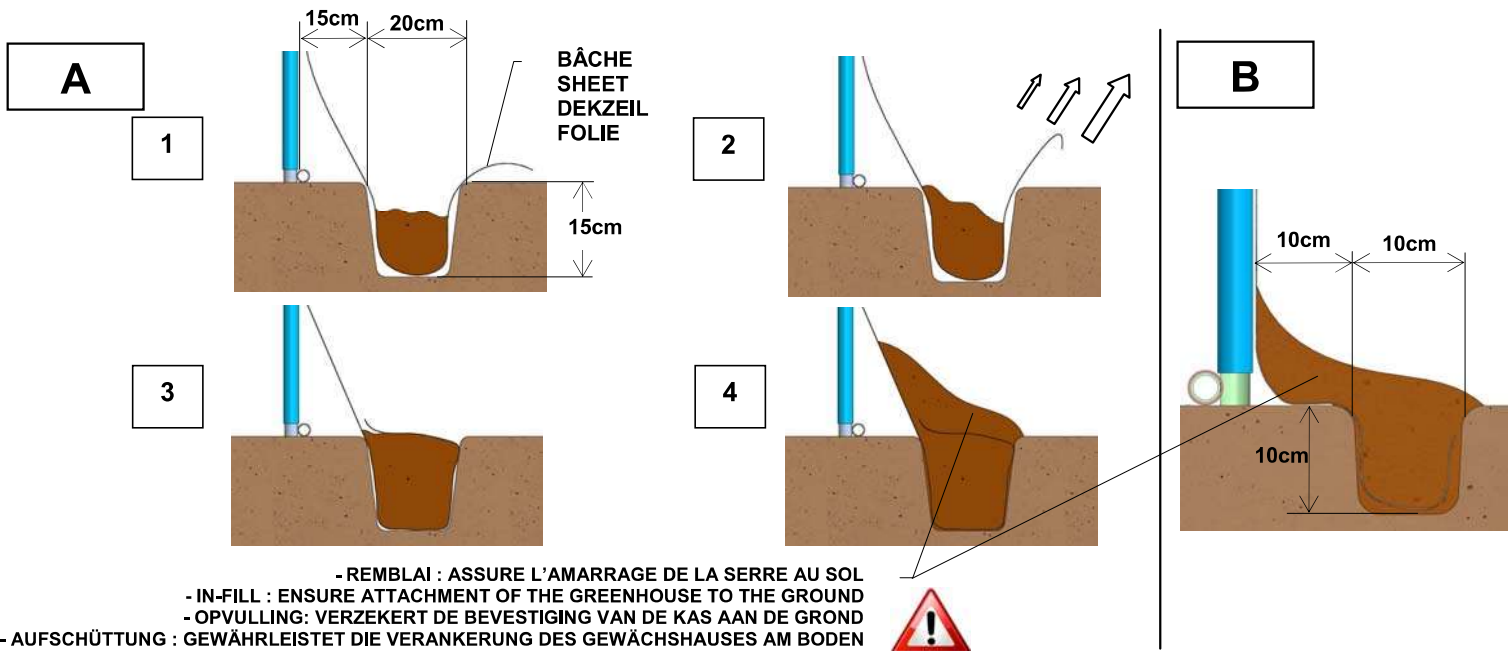
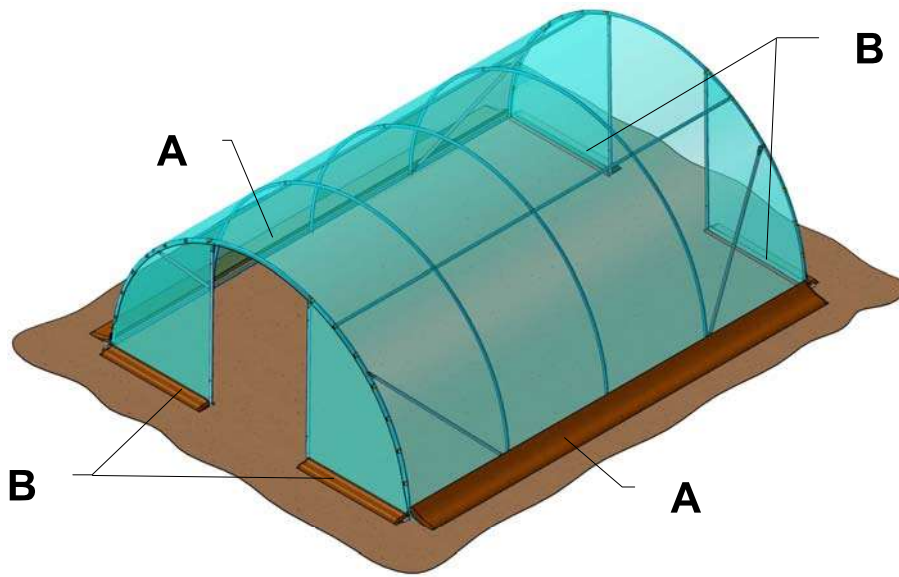

- REMBLAI : ASSURE L'AMARRAGE DE LA SERRE AU SOL
 - IN-FILL : ENSURE ATTACHMENT OF THE GREENHOUSE TO THE GROUND
 - OPVULLING: VERZEKERT DE BEVESTIGING VAN DE KAS AAN DE GROND
 - AUFSCÜTTUNG : GEWÄHRLEISTET DIE VERANKERUNG DES GEWÄCHSHAUSES AM BODEN

Le film doit être parfaitement tendu à la pose et le demeurer, par des vérifications complémentaires régulières, quelles que soient les conditions climatiques extérieures.

En cas de chute de neige, la serre doit être entièrement déneigée.

RESISTANCE AUX PRODUITS CHIMIQUES :

Certains produits chimiques peuvent affecter la résistance au vieillissement des films (produits organo-chlorés, phosphorés, carbamates soufrés, etc.) ; en particulier, certains produits de traitement des cultures, à base de soufre, attaquent les systèmes de stabilisation des films incolores et blancs.

Dans toute la mesure du possible, on évitera les contacts prolongés entre ces produits et les films.

The film must be correctly tightened on installation and stay that way, with regular checks, whatever the weather conditions.
 In the event of snowfall, the greenhouse must be completely cleared of snow.

RESISTANCE TO CHEMICALS :

Certain chemicals can adversely affect the film and reduce its life expectancy (organic chlorides, phosphates, sulphur carbonates, etc.); in particular certain sulphur based crop treatments attack the stabilisers in clear or white films.

As much as possible prolonged contact between these products and the film should be avoided.

Het zeil moet perfect strak worden getrokken. De spanning van het zeil moet regelmatig worden gecontroleerd, ongeacht de weersomstandigheden buiten.

In geval van sneeuwval moet de kas volledig worden ontsneeuwd.

BESTENDIGHEID TEGEN CHEMISCHE PRODUCTEN:

Sommige chemische producten kunnen de weerstand tegen veroudering van het zeil aantasten (organische producten met chloor of fosfor, zwavelurethanen, enz.); met name sommige producten voor de behandeling van gewassen, op basis van zwavel, tasten de stabilisatiesystemen van doorzichtige en witte zeilen aan.

Vermijd, voor zover mogelijk, langdurig contact van deze producten met het zeil.

Die Folie muss bei der Anbringung einwandfrei gespannt werden und so verbleiben. Durch regelmässige zusätzliche Überprüfungen, wie auch immer die äusseren klimatischen Bedingungen aussehen mögen, ist der Sitz der Folie zu überprüfen.

Bei Schneefall ist das Gewächshaus vollständig von Schnee zu befreien.

RESISTENZ GEGENÜBER CHEMISCHEN PRODUKTEN :

Einige chemische Produkte können die Alterungsresistenz der Folien beeinflussen (Organo-chlorierte, phosphorierte, Karbamat- geschwefelte Produkte, usw.) ; insbesondere bestimmte Produkte zur Behandlung der angepflanzten Kulturen auf Schwefelbasis können das Stabilisierungssystem der farblosen und weissen Folien angreifen. So weit es nur geht sollte der verlängerte Kontakt zwischen diesen Produkten und der Folie vermieden werden.

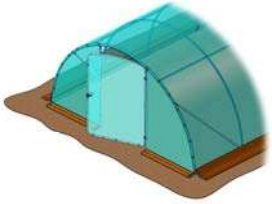

BÄCHE SHEET DEKZEIL FOLIE

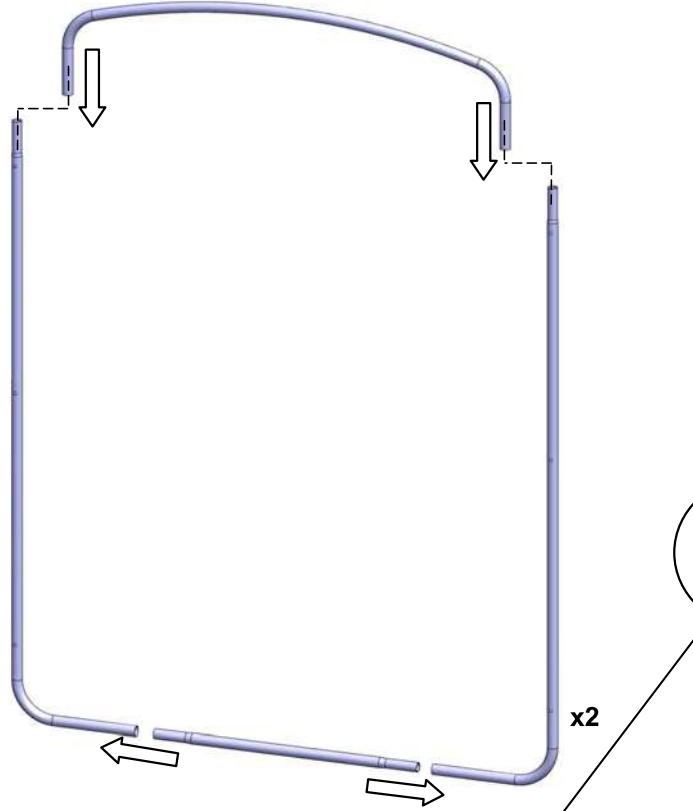

x2

